

auf Druck und Zug

Quick change tapping chucks with length compensation on compression and expansion
 Mandrins de taraudage à changement rapide avec compensation longitudinale à la compression et traction



Verwendung:

Zur Aufnahme von Schnellwechsel-Einsätzen für Gewindebohrer.

Application:

For the chucking of quick change adaptors for taps.

Application:

Pour le serrage d'adaptateurs portetarauds à changement rapide.

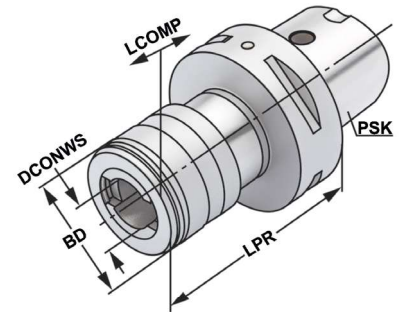

Bestell-Nr. Order no. Référence	PSK	Spannbereich Capacity Capacité	SZID	DCONWS	LPR	BD	LCOMP
C4.16.12	C4	M3 - M14	1	19	80	36	7,5
C4.16.20	C4	M5 - M22	2	31	110	53	12,5
C5.16.12	C5	M3 - M14	1	19	80	36	7,5
C5.16.20	C5	M5 - M22	2	31	115	53	12,5
C6.16.12	C6	M3 - M14	1	19	90	36	7,5
C6.16.20	C6	M5 - M22	2	31	120	53	12,5
C6.16.36	C6	M14 - M36	3	48	170	78	20

Hinweis: Für Bearbeitungszentren ohne Synchronspindel.
Note: For machining centres without synchronous spindle.
Observation: Pour centres d'usinage sans broche synchrone.



10.42



10.43



10.48



10.49



10.50



6.29